

4

3

2

1

Connections			
	Name	Spec.	Fitting
a	Bottom Dump	2	TC
b	Racking Arm	1.5	DIN
c	CIP Inlet	1.5	TC
d	Manway	530x430	Weld
e	Pressure Gauge	1.5	TC
f	Pt100 Thermowell	1.5	TC
g	Thermometer	1.5	TC
h	Sample Valve	1.5	TC
i	PVRV	1.5	TC
j	Hop Port	4	TC
k	CIP Port	4	TC
l	Blow Off Pipe	1.5	TC
m 1-4	Glycol Port	3/4	FNPT
n	CO2 Stone	1.5	TC

Design Data		
Parameter	Vessel	Jacket
Pressure	1 BAR	1 BAR
Design Pressure	2 BAR	4 BAR
Working Temperature	-5 to 40 C	
Design Temperature	-5 to 40 C	
Medium	Beer	
Medium Density	1.040	
Main Compressive Component	304	
Gross Volume	17.8bbl	
Net Volume	15 bbl	
PRV Release	1 BAR	
Cooling Exchange Area	37.8 ft^2	
Insulation	2" PU	

B

B

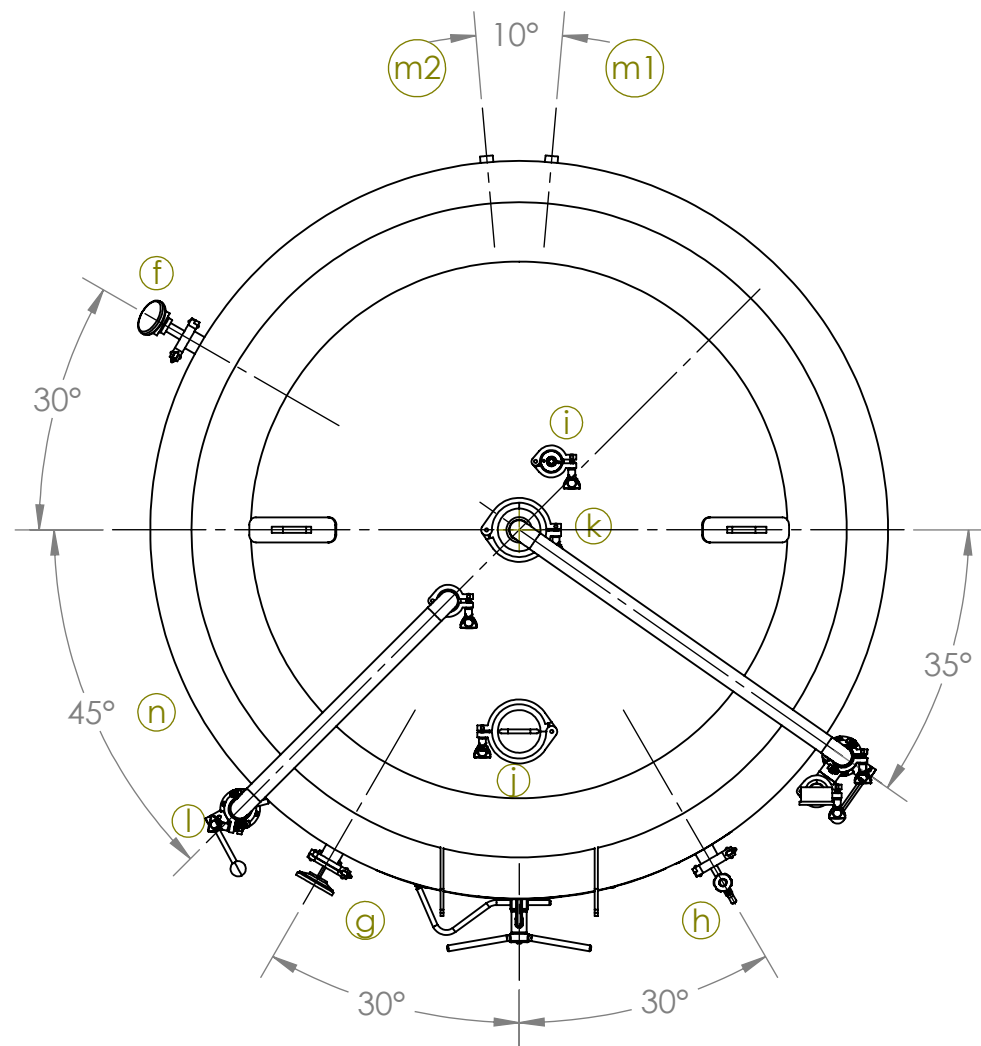
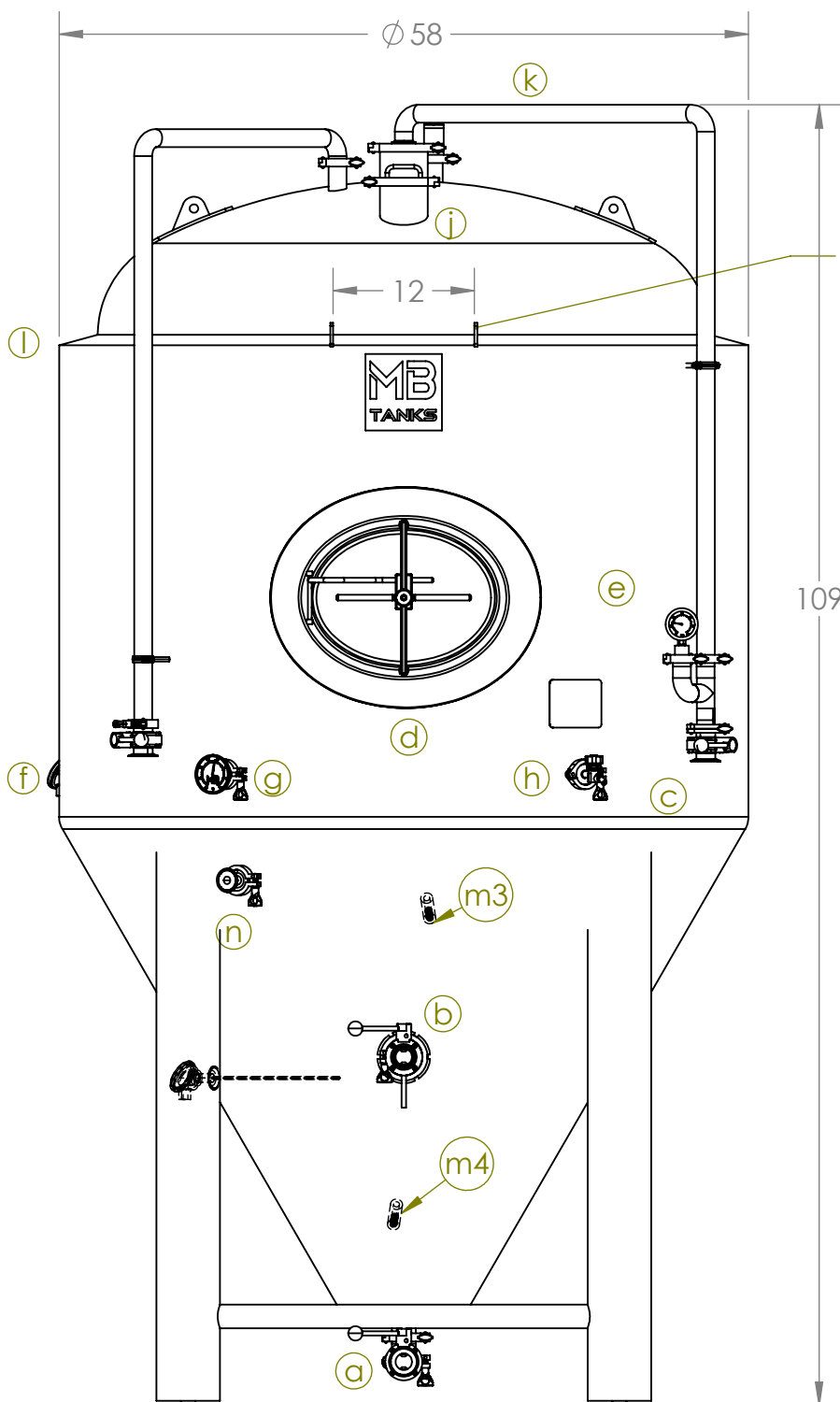

Dimensions	
Height	109
Width	58
Weight	1058

- The inner wall shall be flat. The inner welds shall be ground. Concave cover arris and scratch marks are not allowed.
- Inner Surface
 - The cone & head welding seam shall be polished to Ra < 6 μm.
 - The inner wall shall be 2B finish.
 - The inner surface shall be pickled and passivated
- The outer surface shall be polished to Ra < 1.2 μm
- After tank completion the tank shall be pressure tested to 3 BAR gauge water pressure. The jacket shall be pressure tested to 6 BAR for 12 hours. Testing shall be performed in the upright position.

A

A

MB

PROPRIETARY AND CONFIDENTIAL
 THE INFORMATION CONTAINED IN THIS DRAWING IS THE SOLE PROPERTY OF MOREFLAVOR INC. ANY REPRODUCTION IN PART OR AS A WHOLE WITHOUT THE WRITTEN PERMISSION OF MOREFLAVOR INC. IS PROHIBITED.

DRAWN	NAME	DATE	TITLE: MB Fermenter CON4015-MBV2
CHECKED	CSK	8/10/23	
ENG APPR.			
MFG APPR.			
Q.A.			
COMMENTS: DO NOT SCALE DRAWING DIMENSIONS ARE IN INCHES			SIZE
B	DWG. NO.	15 bbl	REV
1:15	WEIGHT:		2
		SHEET 1 OF 2	

4

3

2

1

4

3

2

1

B

B

A

A

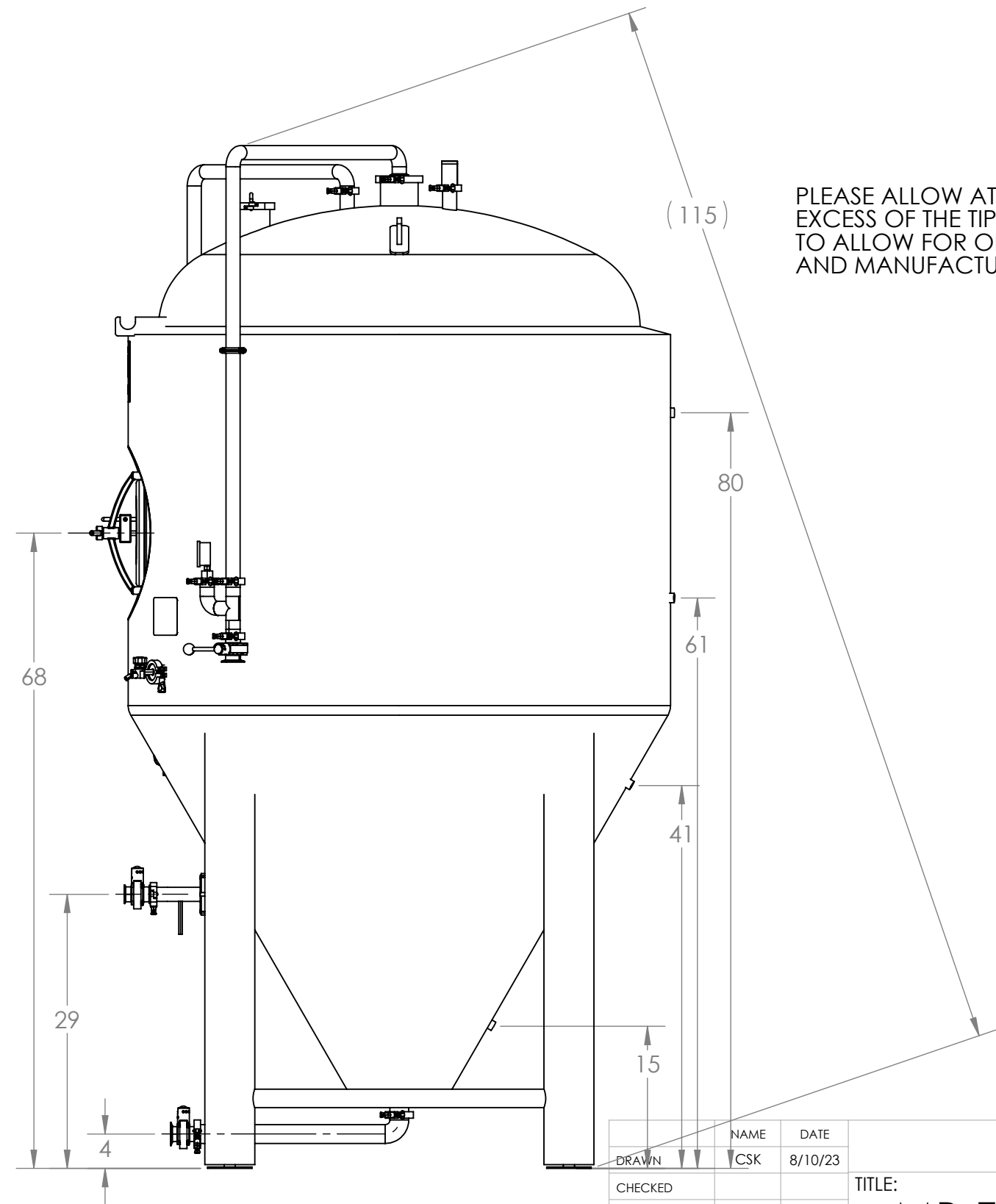
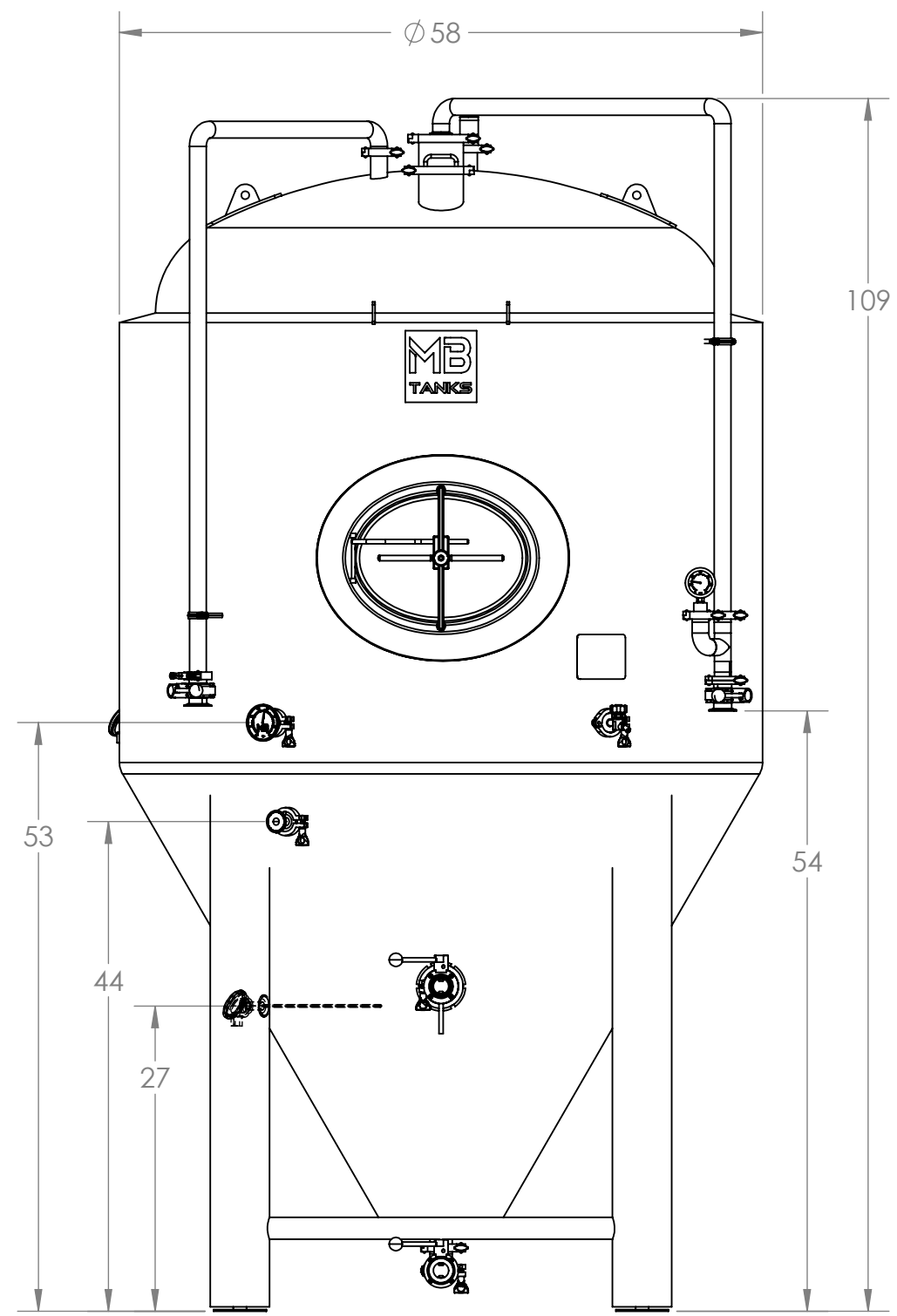

PLEASE ALLOW AT LEAST 4" IN EXCESS OF THE TIPPING MEASUREMENT TO ALLOW FOR ORIENTATION AND MANUFACTURING VARIANCES.



PROPRIETARY AND CONFIDENTIAL
 THE INFORMATION CONTAINED IN THIS DRAWING IS THE SOLE PROPERTY OF MOREFLAVOR INC. ANY REPRODUCTION IN PART OR AS A WHOLE WITHOUT THE WRITTEN PERMISSION OF MOREFLAVOR INC. IS PROHIBITED.

DRAWN	NAME	DATE
CSK		8/10/23

CHECKED	
ENG APPR.	
MFG APPR.	
Q.A.	

COMMENTS:
 DO NOT SCALE DRAWING
 DIMENSIONS ARE IN INCHES

TITLE: MB Fermenter CON4015-MBV2		
SIZE B	DWG. NO. 15 bbl	REV 2
1:15	WEIGHT:	SHEET 2 OF 2

4

3

2

1